



Darren Kuzma is well known in the DIY speaker building community. His designs have proven to be very popular, thanks to his rational assessments of system goals as well as an eye and an ear for important details. We're glad to have him back for an encore as our guest speaker builder!

My last several speaker projects have been somewhat unique and specialized, and were designed for specific applications. It's great when you need a speaker for a particular circumstance, but probably not so good for the average audio enthusiast. As such, when a request came up for a pair of "normal" bookshelf speakers, I was excited at the chance to make a pair of nice all-around compact speakers. Nowadays, it seems difficult to find a compact yet not micro design; many people seem to either gravitate towards extremely small satellites or larger three-ways or MTMs. This speaker fills the niche between these created size extremes.

1 Design Goals

The main goal of this project was to create a compact, high value, full-sounding speaker that would be suitable for a small living room, den, or other average-sized room. I was told that the speakers would be used with a subwoofer when necessary, so they wouldn't need to plumb the depths of bass extension, or produce extremely high SPLs of bass.

One of my personal goals was to create a speaker with a good all-around voicing that would sound good with many different types of music in many different listening situations. I also wanted to use somewhat less baffle step compensation than I usually do, knowing that these speakers would most likely be placed against a wall, on top of a TV, or in some other close-quarters situation that would make the full BSC unnecessary.

2 Driver Selection

To me, the term "compact" usually precludes using any driver bigger than 6" (in my mind, 6-1/2" or greater gets into what I consider average to large speaker sizes.) Since I knew from the outset that these would have a subwoofer available if needed, I figured I would be fine using any of a number of nominal 5-1/4" to 6" drivers. In that size range, I chose the RS150S-8 6" woofer because of its good sonic reputation, high value, and relatively long excursion capabilities compared to other woofers its size.

To go with the RS150S-8, I chose the RS27AS-4 1-1/8" shielded aluminum dome tweeter. This tweeter matches sonically with the woofer very well, and the shielded construction will make for a fully shielded speaker. I know what you're thinking—I've used this tweeter a lot. But what can I say?—I like it!

3 Enclosure Design

Since one of the main goals of this speaker was compactness, a single woofer two-way design was chosen to help keep the enclosure size to a minimum. Believe it or not, a single 5-1/4" or 6" woofer can produce some fairly substantial bass and can really surprise a person with its full range capabilities. I've built and heard many DIY and commercial high-end 5-1/4" two-ways that really impressed me with their bass and overall output capabilities.

THE ENCORE



The RS150S-8 has parameters that make it suitable for both sealed and vented enclosures, and for the purposes of this article, I will outline both options. The speakers as built use a small, sealed enclosure of .25 cu. ft. This sealed alignment produces an F3 of approximately 80 Hz—perfect for use with a subwoofer. The Dayton TW-0.25 .25 cu. ft. speaker cabinets are an excellent choice for this alignment, or you could build your own 12" H x 7.5" W x 10" D cabinets.

The vented alignment with this woofer would be the more suitable option for stand alone use in a bedroom or similar situation. In my opinion, one of the tricks to getting "solid" bass out of a smaller driver like the RS150S-8 is to use a vented enclosure that is not tuned overly low. For whatever reason, most of the 5-1/4" two-ways that I have liked best in the bass area have F3s around 60 Hz with tunings around 50 Hz. This helps to create tight, punchy bass that sounds like the bass one would expect from a small speaker.

To get a tuning in this range with the RS150S-8, we need an enclosure of approximately .35 cu. ft., with a 1-1/2" x 4" port. It just so happens that the Dayton TW-0.38 .38 cu. ft. cabinet nearly matches the desired cabinet volume, and would be an excellent choice. For those that want to build their own cabinet, the external dimensions are 14" H x 8" W x 12" D.

4 Enclosure Construction & Assembly

Since I used the Dayton pre-fabricated cabinets, construction was fairly limited from my end, and involved making the cutouts for the drivers and ports. For the baffles, I used a router with the Jasper Circle Cutting Jig to make the recesses and through-holes. As always, I made sure to protect my baffle finish with some masking material; in this case I applied a few strips of 3" blue painter's tape.

Look for These Products

Woofer – #295-362



Tweeter – #275-135



Cabinets – #302-704



**Turn to page 15 for more information on items featured in this article.*

THE ENCORE

Parts List

Part #	Description	Qty.
004-4	Dayton 4 ohm non-inductive resistor	2
004-8	Dayton 8 ohm non-inductive resistor	2
027-426	Dayton 8.2 uF polypropylene capacitor	2
027-427	Dayton 6.2 uF polypropylene capacitor	2
027-434	Dayton 18 uF polypropylene capacitor	2
027-438	Dayton 25 uF polypropylene capacitor	2
091-1245	Dayton gold binding post pair	2
255-198	Jantzen .025 mH 18 ga air core inductor	2
255-216	Jantzen .27 mH 18 ga air core inductor	2
255-242	Jantzen .8 mH 18 ga air core inductor	2
255-260	Jantzen 1.5 mH 18 ga air core inductor	2
260-516	1-1/2" acoustic foam	1
275-135	Dayton RS28AS-4 1-1/8" shielded tweeter	2
295-364	Dayton RS150S-8 6" shielded woofer	2
302-704	Dayton TW-.25BE cabinet pair	1

Overall Dimensions

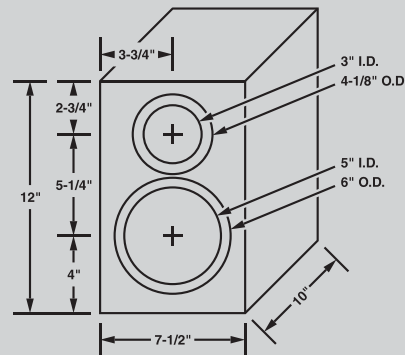

Crossover Schematic

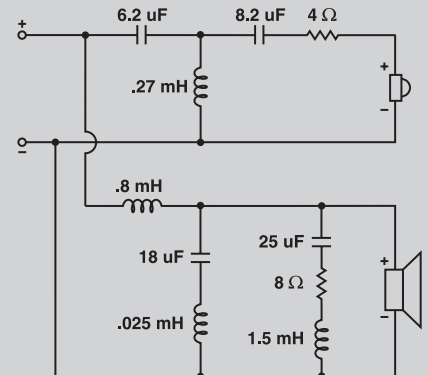

Listeners' Comments

Mike: Small in stature, though big on sound, these speakers did not disappoint. The size lends itself to many applications: surround satellites, near-field monitors, or even as computer speakers. With a bass response that was accurate though lean, a subwoofer will be needed to augment the lowest two octaves. The Dayton Reference Series needs no further superlative.

Karl: My first thought was—too small for acceptable bass output, but after listening to them that impression quickly changed. These speakers delivered tight lower midbass and had an audiophile-quality sound for music. Great for music in small listening rooms or as satellites in a home theater system.

Brian: These speakers are very musical and accurate with precise imaging that provides a soundstage with depth and clarity. Substantial output from such a small speaker system.

For cutting the ports on the rear of the cabinet, I chose to use a hole saw instead of a router. The hole saw produces a less precise cutout, but can be quicker in setup time and less dusty. In situations where the hole will be covered by a plastic terminal or port, I find the hole saw technique to be perfectly legitimate.

I'd like to share a little trick I developed when it comes to using a hole saw in MDF, which normally doesn't work very well. Start by using the hole saw as normal to begin the cut. However, once the circular portion of the saw gets a short ways into the wood, stop drilling and take the hole saw away from the wood. Now, using a roughly 1/8" drill bit, drill several holes through the wood along the circumference of the hole saw cut. These extra holes will provide a place for the MDF dust to eject from the hole saw teeth, eliminating the burning and binding that usually occurs. With this technique, you should be able to do the remainder of the hole in one pass.

Frequency Response Chart

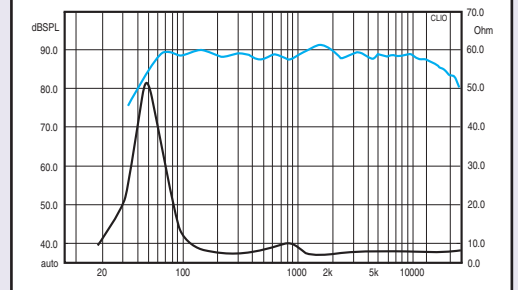

5 Crossover Design

When it came time to design the crossovers for these speakers, I chose to shoot for fourth order acoustic slopes. Second order slopes would certainly be an option, but I often find that it takes less components to achieve a fourth order slope, especially with drivers that need a little extra attention in their breakup regions.

To achieve the fourth order acoustic slope on the woofer, I used what is essentially a second order electrical cutoff plus a notch filter. The notch filter is primarily used as the means of baffle step compensation. Because of the nature of the baffle step, small speakers tend to suffer from a sharper transition from 2 pi to 4 pi space, and it occurs at a higher frequency. In my experience, using a notch filter in these situations can be more effective compared to conventional BSC filters.

The tweeter utilizes a simple third order electrical filter with a single resistor for attenuation. Together, the net crossover point between the woofer and tweeter is 2300 Hz.

Visit parts-express.com for more great DIY projects!

6 Comments & Conclusions

For a sealed 6" two-way design, these speakers are amazingly compact and aesthetically very robust. Even in their larger, vented form, they are still very compact in size and manageable for most rooms. The sealed enclosure version is great when used with a subwoofer, and is very good at providing a "big" sound in a small package. The vented enclosure version holds its own over the entire range, including the bass department.

Tonally, these speakers met my initial goals of having a somewhat laid-back sound that works well with many types of music. They are very accurate, yet not harsh or overly revealing. When used properly, these speakers can handle a healthy amount of power and produce SPLs that will fill any reasonably sized room. Overall, these are great all-around compact speakers that will excel in a myriad of applications.



About the Designer

Darren Kuzma has been a speaker building enthusiast for many years, and enjoys creating speakers that are unique and out-of-the-ordinary. His designs combine solid technical design principles with creative shapes, colors, and materials. When asked how he learned about the hobby he said "I've learned the most by talking to other speaker builders, reading, doing experiments, and by trial-and-error. There's nothing like getting your hands dirty, that's why they call it DIY!"

